



HYDRA-TECH PUMPS

PORTABLE HYDRAULIC POWER UNIT

MODEL HT100DJV



Unit shown with optional highway trailer

Our high performance 100 H.P. model features a John Deere turbocharged 4 cylinder diesel and pressure compensated hydraulic pump. It is designed to drive our larger submersible pumps or other hydraulic equipment requiring flows to 53 GPM and pressures to 2500 PSI.

FEATURES

- Skid Frame Chassis with built-in Extended-run Fuel Tank and fork-lift slots
- Single Point Lifting Bracket and Tie Downs for Transport
- Automatic Engine Safety Shutdown
- Variable Piston Hydraulic Pump
- Efficient Hydraulic Oil Cooler
- Spin-On Return Filter w/Indicator
- Variable Speed Control
- Tank Top Filler/ Strainer
- System Relief Valve
- Pressure Control Valve
- Liquid Filled Pressure Gauge
- Fluid Level/ Temperature Gauge

OPTIONS

- Highway Trailer with Independent Suspension
- D.O.T. Brakes and Lights
- Multiple Hydraulic Circuits
- Other Flow and Pressure Combinations

C0309



**HYDRA-TECH
PUMPS**

167 Stock Street, Nesquehoning, PA 18240 Phone: 570-645-3779 Fax: 570-645-4061
Website: www.hydra-tech.com E-Mail: htpump@hydra-tech.com

Model HT100DJV Overall Dimensions

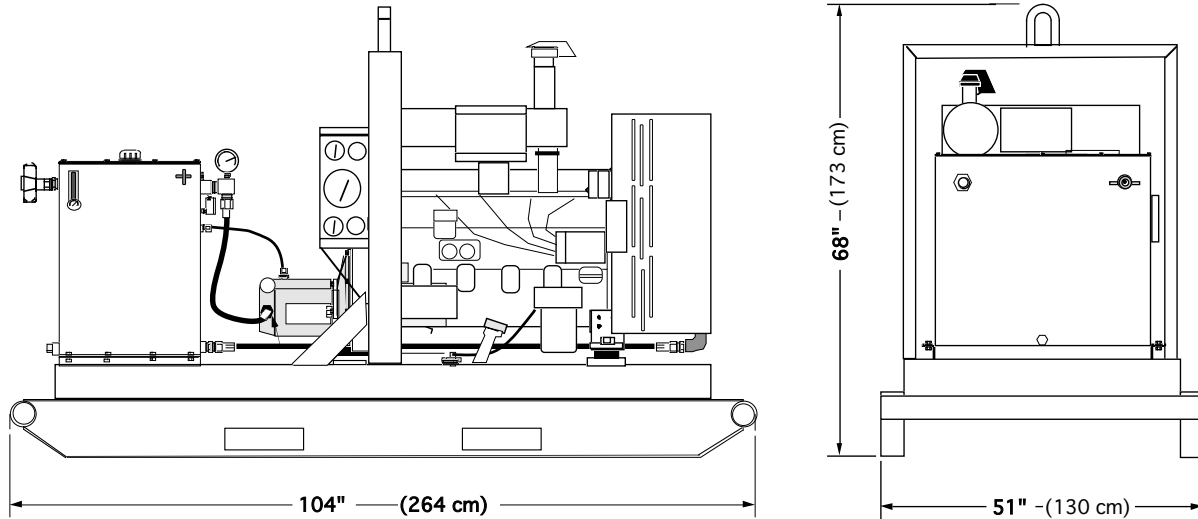

SPECIFICATIONS

ENGINE:..... John Deere 4045T285 Diesel (Tier 3)
HORSE POWER:..... 99 @ 2300 RPM
HYDRAULIC OUTPUT*:..... Variable Max 53 GPM (201 LPM)
OPERATING PRESSURE*:..... Maximum 2500 PSI (170 Bar)
HOSE PORT SIZE:..... 1 1/4" NPT
HYDRAULIC OIL:..... SAE 10W or 20W Type AW
also: Biodegradable oil (Consult Factory)
OIL FILTRATION:..... 10 Micron (Standard)
OIL RESERVOIR CAPACITY:..... 75 U.S. Gallons (284 Liters)
FUEL TANK CAPACITY:..... 88 U.S. Gallons (333 Liters)
FUEL CONSUMPTION:..... Approx. 4.5 U.S. Gal/Hr (17 Liters/Hr)
DIMENSIONS:..... H 68" (173 cm) x W 51" (130 cm) x L 104" (264 cm)
WEIGHT (Dry):..... 2800 lbs. (1268 kg)

* For Flows and Pressures Other Than Standard, Consult Factory

Since we are constantly working to improve our products, specifications are subject to change without notice.



167 Stock Street, Nesquehoning, PA 18240 Phone: 570-645-3779 Fax: 570-645-4061
Website: www.hydra-tech.com E-Mail: htpump@hydra-tech.com