



HYDRA-TECH PUMPS

PORTABLE HYDRAULIC POWER UNIT

MODEL HT11D

This portable diesel power pack is ideal for driving our 3" trash pumps and even our 6" high-volume propeller pump. It also can provide hydraulic power to run many other hydraulic tools now available.



Unit shown with optional wheel kit

FEATURES

- Yanmar air-cooled Diesel Engine with Electric Start
- Roll Cage Frame with Single Point Lifting Eye
- Gear-Type Hydraulic Pump
- Spin-On Return Filter W/ Indicator
- Variable Speed Control
- Hydraulic Oil Cooler
- Tank Top Filler/ Strainer
- HTMA Quick - Disconnect Couplings
- System Relief Valve
- Pressure Control Valve
- Liquid Filled Pressure Gauge
- Fluid Level/ Temperature Gauge

OPTIONS

- Wheel Kit
- Other Flow and Pressure Combinations

C0109



**HYDRA-TECH
PUMPS**

167 Stock Street, Nesquehoning, PA 18240 Phone: 570-645-3779 Fax: 570-645-4061
Website: www.hydra-tech.com E-Mail: htpump@hydra-tech.com

Model HT11D Overall Dimensions

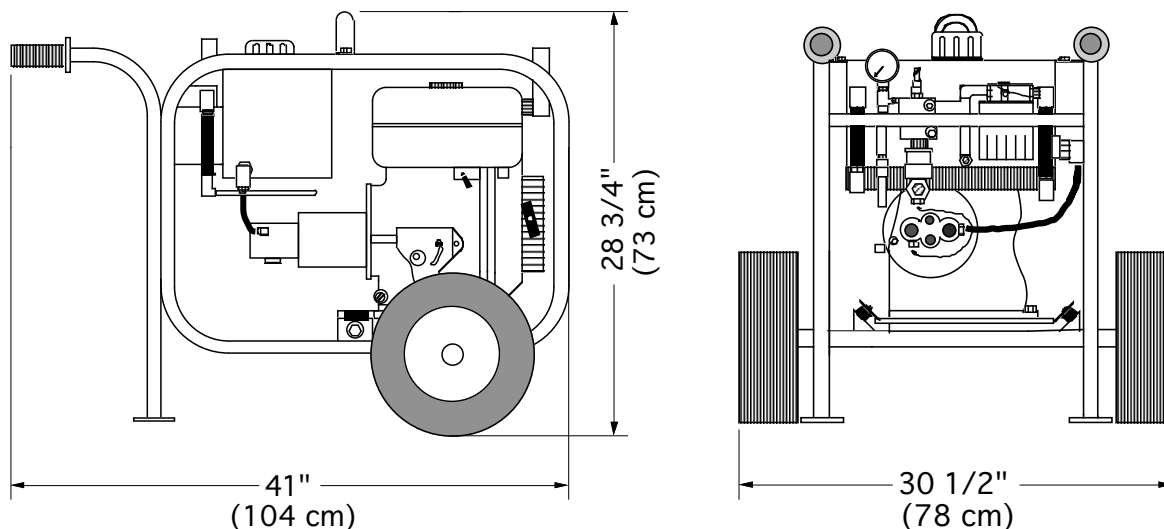

SPECIFICATIONS

ENGINE:..... Yanmar L100V Diesel
HORSE POWER:..... 11 @ 3500 RPM
HYDRAULIC OUTPUT:..... Variable Max 6 GPM (23 LPM)
OPERATING PRESSURE:..... Maximum 2100 PSI (143 Bar)
HOSE PORT SIZE:..... 1/2" NPT
HYDRAULIC OIL:..... SAE 10W or 20W Type AW
also...Dexron ATF or Biodegradable Oil
OIL FILTRATION:.....10 Micron (Standard)
OIL RESERVOIR CAPACITY:..... 4 U.S. Gallons (15.1 Liters)
FUEL TANK CAPACITY:..... 1.45 U.S. Gallons (5.5 Liters)
FUEL CONSUMPTION:..... Approx. .5 U.S. Gal/Hr (1.9 Liters/Hr)
DIMENSIONS:..... H 25" (63.5 cm) x W 20" (51 cm) x L 30" (76 cm)
w/ Wheel Kit: H 28 3/4" (73 cm) x W 30 1/2" (78 cm) x L 41" (104 cm)
WEIGHT (Dry):..... 225lbs. (102 kg)

* For Flows and Pressures Other Than Standard, Consult Factory

Since we are constantly working to improve our products, specifications are subject to change without notice.



167 Stock Street, Nesquehoning, PA 18240 Phone: 570-645-3779 Fax: 570-645-4061
Website: www.hydra-tech.com E-Mail: htpump@hydra-tech.com