



HYDRA-TECH PUMPS

PORTABLE HYDRAULIC POWER UNIT

MODEL HT25DD

This power unit is driven by a Deutz air-cooled diesel engine and is designed to drive several of our pump models including the S4T, S4CSL and S8M. A large, built-in fuel tank allows this unit to run up to 24 hours between refills. Other equipment that require flows to 15 GPM may also operate from this power unit.



FEATURES

- Highway Trailer Chassis with Built-In Fuel Tank and Independent Suspension
- Single Point Lifting Bracket
- Automatic Engine Safety Shutdown Package
- Vane-Type Hydraulic Pump
- Spin-On Return Filter W/ Indicator
- Variable Speed Control
- Tank Top Filler/ Strainer
- System Relief Valve
- Pressure Control Valve
- Liquid Filled Pressure Gauge
- Fluid Level/ Temperature Gauge

OPTIONS

- Skid Frame
- Multiple Hydraulic Circuits
- Other Flow and Pressure Combinations

B0109



**HYDRA-TECH
PUMPS**

167 Stock Street, Nesquehoning, PA 18240 Phone: 570-645-3779 Fax: 570-645-4061
Website: www.hydra-tech.com E-Mail: htpump@hydra-tech.com

Model HT25DD Overall Dimensions

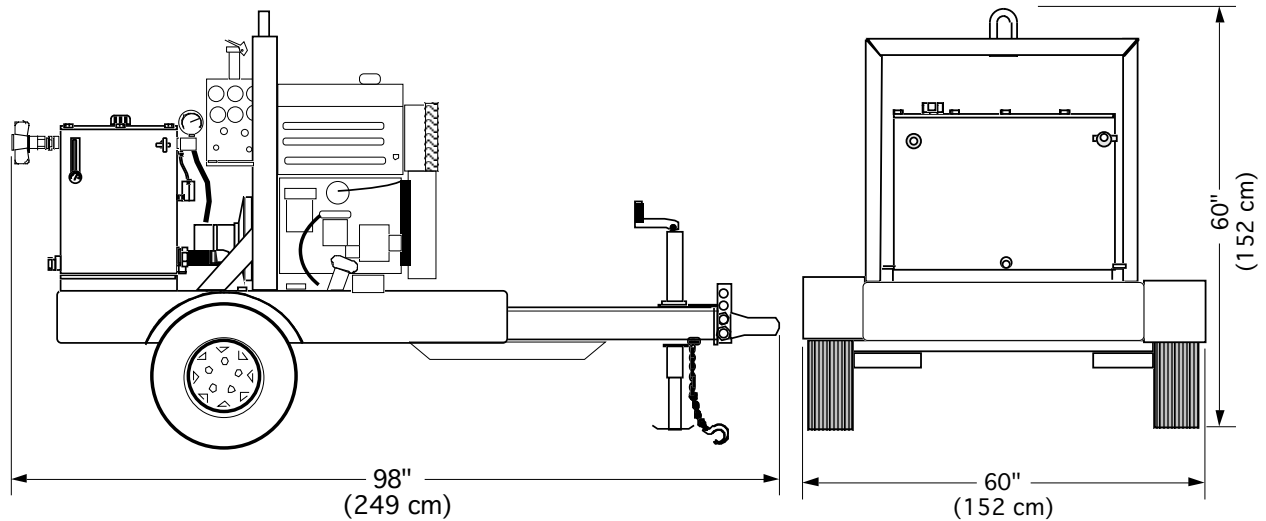

SPECIFICATIONS

ENGINE:..... Deutz D2011L02 Air Cooled Diesel (Tier 3)
HORSEPOWER:..... 25 @ 2300 RPM
HYDRAULIC OUTPUT*:..... Variable, Max. 15 GPM (57 LPM)
OPERATING PRESSURE*:..... Maximum 2500 PSI (170 Bar)
HOSE PORT SIZE:..... 3/4" NPT
HYDRAULIC OIL:..... SAE 10W or 20W Type AW
..... also: Biodegradable oil (Consult Factory)
OIL FILTRATION:.....10 Micron (Standard)
OIL RESERVOIR CAPACITY:..... 30 U.S. Gallons (114 Liters)
FUEL TANK CAPACITY:..... 37 U.S. Gallons (140 Liters)
FUEL CONSUMPTION:..... Approx. 1.2 U.S. Gal/Hr (4.5 Liters/Hr)
DIMENSIONS:..... H 60" (152 cm) x W 60" (152 cm) x L 98" (249 cm)
WEIGHT (Dry):..... 1380 lbs. (625 kg)

* For Flows and Pressures Other Than Standard, Consult Factory

Since we are constantly working to improve our products, specifications are subject to change without notice.



167 Stock Street, Nesquehoning, PA 18240 Phone: 570-645-3779 Fax: 570-645-4061
Website: www.hydra-tech.com E-Mail: htpump@hydra-tech.com