



# HYDRA-TECH PUMPS

## PORTABLE HYDRAULIC POWER UNIT

### MODEL HT35DYS

This diesel power unit is powered by a Yanmar diesel engine and is designed to drive several of our pump models including the S4VHL and S6TC. A large, built-in fuel tank allows this unit to run up to 24 hours between refills. Other equipment that require flows to 20 GPM may also operate from this power unit.

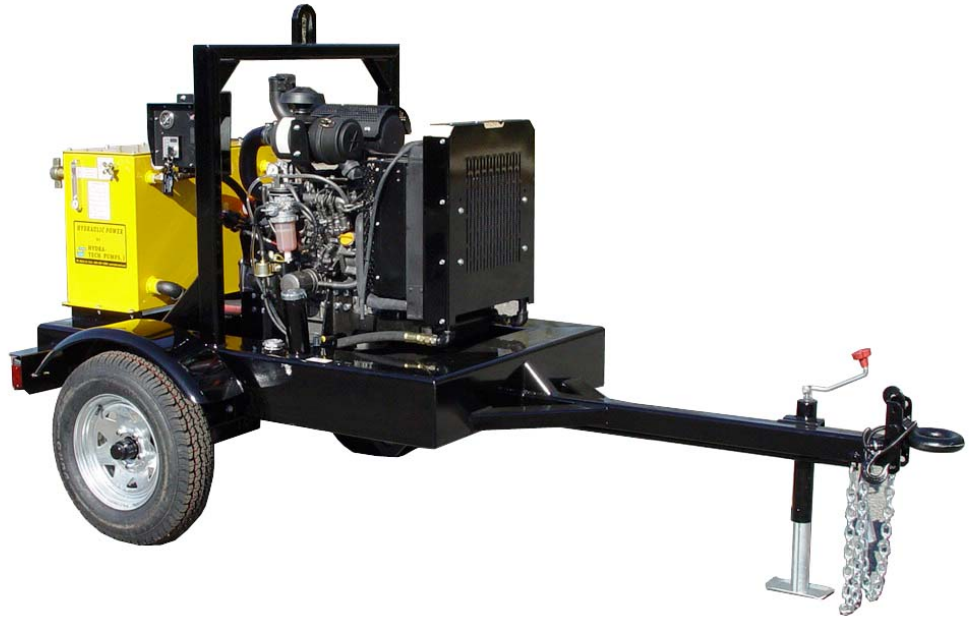

## FEATURES

- Highway Trailer Chassis with Built-In Fuel Tank and Independent Suspension
- Single Point Lifting Bracket
- Automatic Engine Safety Shutdown
- Vane-Type Hydraulic Pump
- Hydraulic Oil Cooler
- Variable Speed Control
- Spin-On Return Filter W/ Indicator
- Tank Top Filler/ Strainer
- System Relief Valve
- Pressure Control Valve
- Liquid Filled Pressure Gauge
- Fluid Level/ Temperature Gauge

### OPTIONS

- Skid Frame
- Multiple Hydraulic Circuits
- Other Flow and Pressure Combinations

B0209



**HYDRA-TECH  
PUMPS**

167 Stock Street, Nesquehoning, PA 18240 Phone: 570-645-3779 Fax: 570-645-4061  
Website: [www.hydra-tech.com](http://www.hydra-tech.com) E-Mail: [htpump@hydra-tech.com](mailto:htpump@hydra-tech.com)

## Model HT35DYS Overall Dimensions

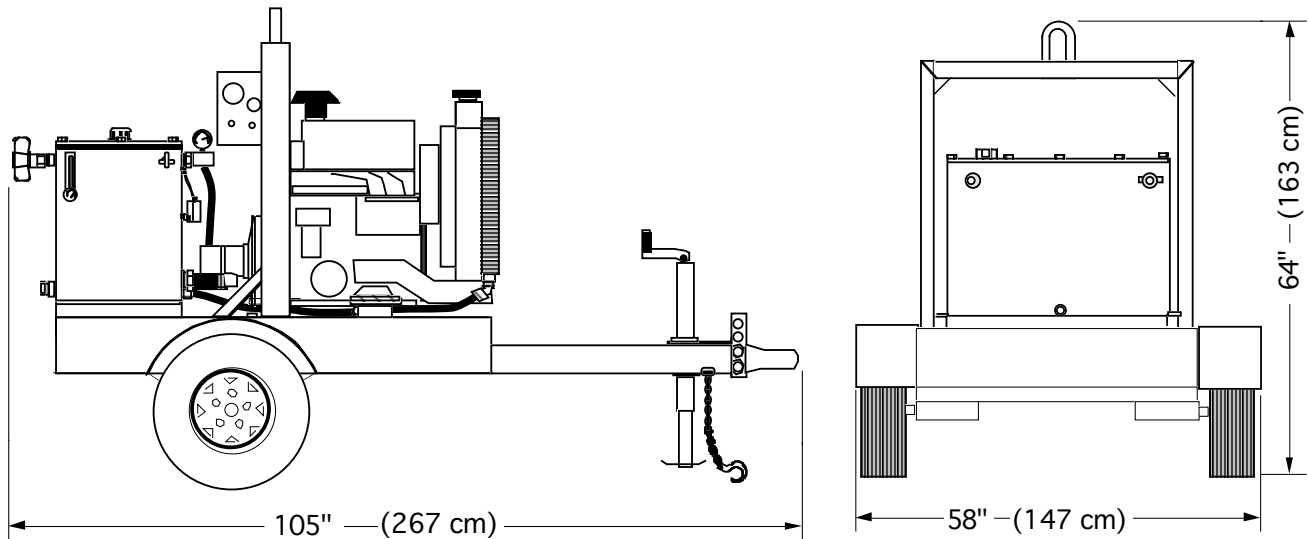

## SPECIFICATIONS

ENGINE:..... Yanmar 3TNV88 Liquid Cooled Diesel (Tier 4 Int.)  
POWER:..... 35 HP(26 KW) @ 3000 RPM  
HYDRAULIC OUTPUT\*..... Variable, Max. 20 GPM (76 LPM)  
OPERATING PRESSURE\*..... Maximum 2500 PSI (170 Bar)  
HOSE PORT SIZE:..... 3/4" NPT  
HYDRAULIC OIL:..... SAE 10W or 20W (ISO 32 or 46) Type AW  
..... also: Biodegradable oil (Consult Factory)  
OIL FILTRATION:..... 10 Micron (Standard)  
OIL RESERVOIR CAPACITY:..... 30 U.S. Gallons (113 Liters)  
FUEL TANK CAPACITY:..... 42 U.S. Gallons (159 Liters)  
FUEL CONSUMPTION:..... Approx. 1.5 U.S. Gal/Hr (5.7 Liters/Hr)  
DIMENSIONS:..... H 64" (163 cm) x W 58" (147 cm) x L 105" (267 cm)  
WEIGHT (Dry):..... 1420 lbs. (643 kg)

\* For Flows and Pressures Other Than Standard, Consult Factory

Since we are constantly working to improve our products, specifications are subject to change without notice.



167 Stock Street, Nesquehoning, PA 18240 Phone: 570-645-3779 Fax: 570-645-4061  
Website: [www.hydra-tech.com](http://www.hydra-tech.com) E-Mail: [htpump@hydra-tech.com](mailto:htpump@hydra-tech.com)