



# HYDRA-TECH PUMPS

## PORTABLE HYDRAULIC POWER UNIT

### MODEL HT60DJV



This popular unit features a John Deere diesel engine and pressure compensated hydraulic pump for maximum versatility and enhanced performance when driving our submersible pumps.

Unit shown with optional hydraulic brakes and lighting kit

## FEATURES

- Highway Trailer Chassis with built-in extended-run fuel tank and independent suspension
- Single Point Lifting Bracket and Tie Downs for Transport
- Automatic Engine Safety Shutdown
- Variable Piston Hydraulic Pump
- Efficient Hydraulic Oil Cooler
- Spin-On Return Filter w/Indicator
- Variable Speed Control
- Tank Top Filler/ Strainer
- System Relief Valve
- Pressure Control Valve
- Liquid Filled Pressure Gauge
- Fluid Level/ Temperature Gauge

### **OPTIONS**

- D.O.T. Brakes and Lights
- Skid Frame
- Multiple Hydraulic Circuits
- Other Flow and Pressure Combinations

B0109



**HYDRA-TECH  
PUMPS**

167 Stock Street, Nesquehoning, PA 18240 Phone: 570-645-3779 Fax: 570-645-4061  
Website: [www.hydra-tech.com](http://www.hydra-tech.com) E-Mail: [htpump@hydra-tech.com](mailto:htpump@hydra-tech.com)

## Model HT60DJV Overall Dimensions

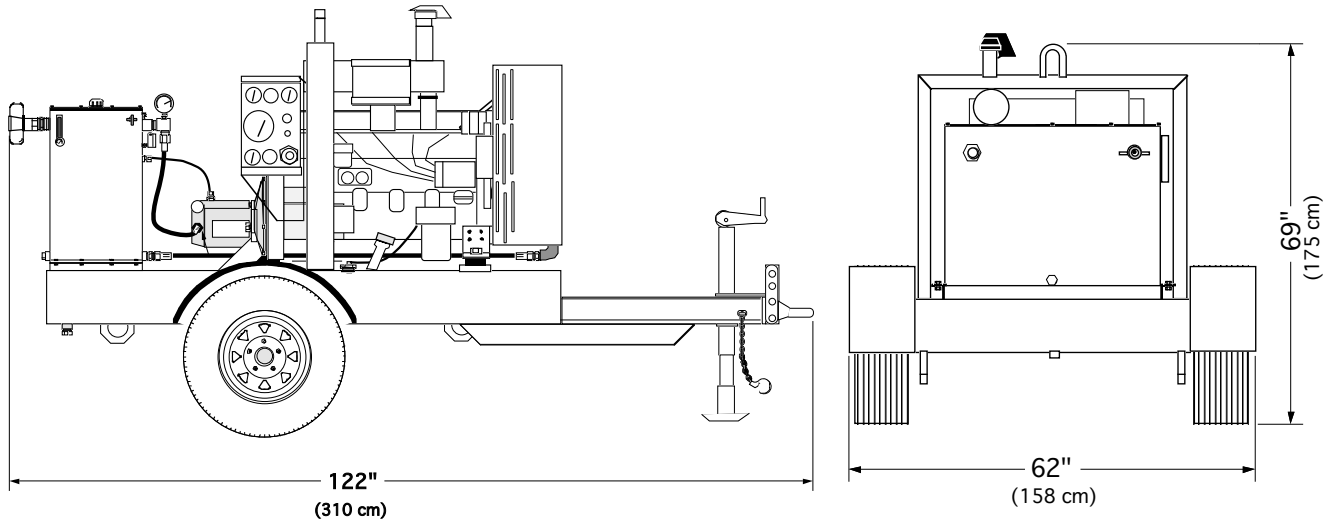

## SPECIFICATIONS

ENGINE:..... John Deere 4045T280 Diesel (Tier 3)  
HORSE POWER:..... 72 @ 2300 RPM  
HYDRAULIC OUTPUT\*:..... Variable Max 26 GPM (98 LPM)  
OPERATING PRESSURE\*:..... Maximum 2900 PSI (197 Bar)  
HOSE PORT SIZE:..... 1" NPT  
HYDRAULIC OIL:..... SAE 10W or 20W Type AW  
also: Biodegradable oil (Consult Factory)  
OIL FILTRATION:..... 10 Micron (Standard)  
OIL RESERVOIR CAPACITY:..... 50 U.S. Gallons (190 Liters)  
FUEL TANK CAPACITY:..... 81 U.S. Gallons (307 Liters)  
FUEL CONSUMPTION:..... Approx. 2.8 U.S. Gal/Hr (10.6 Liters/Hr)  
DIMENSIONS:..... H 69" (175 cm) x W 62" (158 cm) x L 122" (310 cm)  
WEIGHT (Dry):..... 2460 lbs. (1114 kg)

\* For Flows and Pressures Other Than Standard, Consult Factory

Since we are constantly working to improve our products, specifications are subject to change without notice.



167 Stock Street, Nesquehoning, PA 18240 Phone: 570-645-3779 Fax: 570-645-4061  
Website: [www.hydra-tech.com](http://www.hydra-tech.com) E-Mail: [htpump@hydra-tech.com](mailto:htpump@hydra-tech.com)