



# HYDRA-TECH PUMPS

## 2" HYDRAULIC SUBMERSIBLE TRASH PUMP

**MODEL S2T-2 (Ductile Iron Body)**

**MODEL S2TAL-2 (Aluminum Body)**

2" (50mm) Discharge

The S2T-2 is a Very Portable Vortex Impeller pump. This pump can handle stringy solids and can be used for jobs such as bilge pumping, jobsite dewatering, wastewater transfer, oil skimmers, vault pumping and grit chamber clean-outs.



### FEATURES

- Fully Recessed Vortex Impeller (will Pass 1 1/2" [38mm] Semi-Solids)
- Rugged and Reliable gerotor motor
- Variable Speed hydraulic drive
- Small Overall Size makes this pump very versatile
- Can be bolted directly into a pipeline
- Safe Hydraulic Drive can be used where electric power is hazardous or impractical
- Operates with our HT6 and HT7 power units or other hydraulic power sources capable of flows to 5 GPM

### SPECIFICATIONS

WEIGHT: S2T-2.....	25 lbs. (11 kg)
S2TAL-2.....	17 lbs. (7.7 kg)
HEIGHT:.....	13" (33 cm)
WIDTH (@ widest point):.....	9 3/8" (24 cm)
DISCHARGE:.....	2" NPT(F)
INLET FLANGE:.....	1 1/2" 125#
SOLIDS HANDLING:.....	1 1/2" (38mm)
HOSE PORTS:.....	3/8" SAE (-6) 'O' Ring
PUMP BODY: S2T-2.....	Ductile Iron
S2TAL-2.....	Aluminum
IMPELLER:.....	Ductile Iron
SHAFT:.....	Heat Treated Steel Alloy
SHAFT SEAL:.....	Carbon/Ceramic (Std)
ELASTOMERS:.....	Buna N (Std)
HYDRAULIC OIL:.....	214-320 s.s.u. @ 100°F (64°C)
INPUT FLOW:.....	Max. 5 GPM (19 LPM)
OPERATING PRESSURE:....	Cont. Max: 2000PSI (136 Bar)
	Int. Max: 2500 PSI (172 Bar)
POWER SOURCE:.....	Any Open Center Hydraulic System

D0109

Specifications are subject to change without notice



167 Stock Street, Nesquehoning, PA 18240 Phone: 570-645-3779 Fax: 570-645-4061  
Website: [www.hydra-tech.com](http://www.hydra-tech.com) E-Mail: [htpump@hydra-tech.com](mailto:htpump@hydra-tech.com)

## Model S2T-2 Overall Dimensions

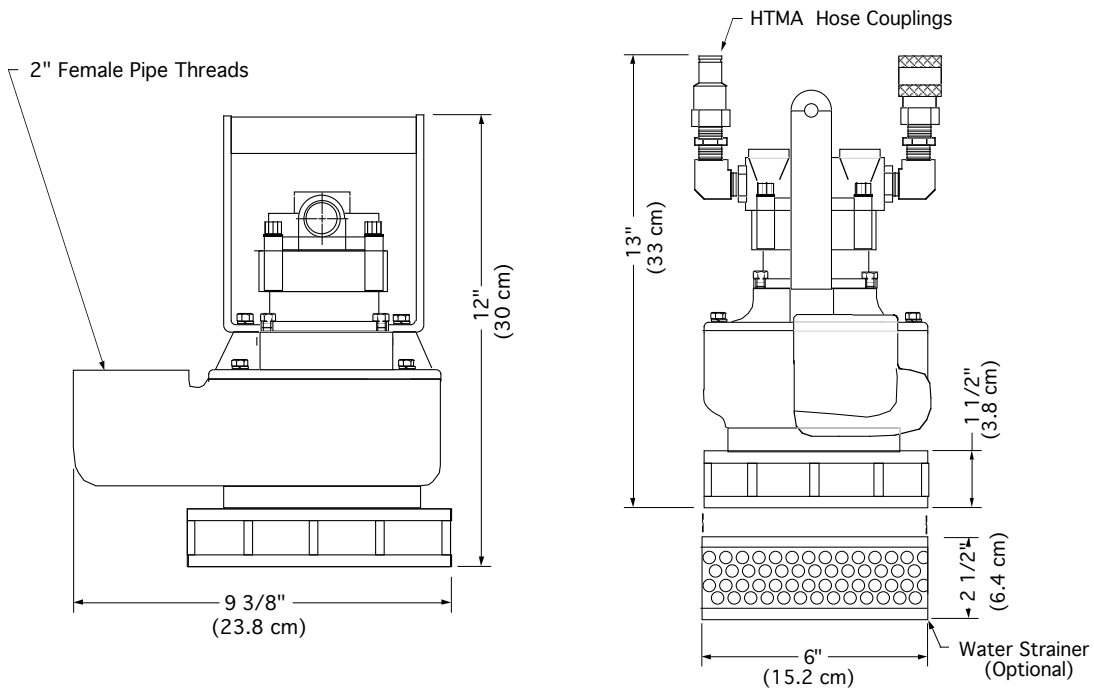

## S2T-2 Typical Performance

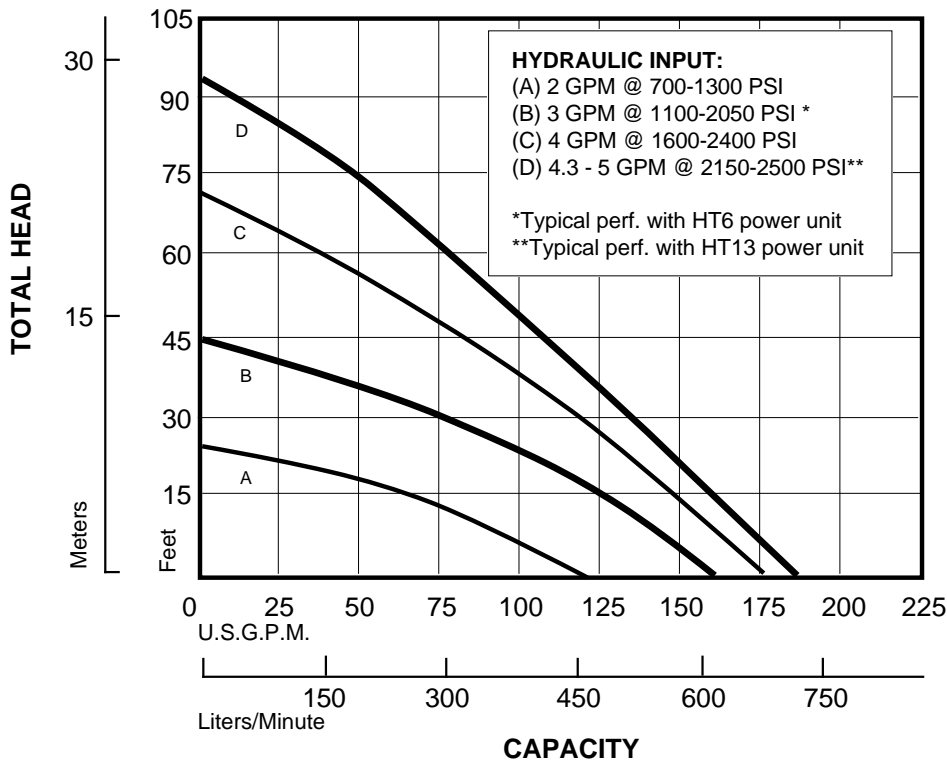

Curves are based on pumping water at 60°F. For performance curves other than shown above, consult factory.