



HYDRA-TECH PUMPS

3" HYDRAULIC SUBMERSIBLE SLIM-LINE PUMP

MODEL S3A

3" (75mm) Discharge

The S3A is designed to be used as a dewatering pump in areas where space is limited. Typical uses for this pump include manhole, vault, blasthole, mine and construction jobsite dewatering.



FEATURES

- Hardened Stainless Steel Impeller resists wear
- Rubber Coated Suction Case resists abrasion
- Small Overall Size allows pump to fit through 8" diameter opening
- Oil Lubricated Seals (can run dry)
- Variable Speed hydraulic drive
- Safe Hydraulic Drive can be used where electric power is hazardous or impractical
- Dependable gear type hydraulic motor
- Operates with our HT15 to HT25 power units or other hydraulic power sources capable of flows to 12 GPM

SPECIFICATIONS

WEIGHT:	41 lbs. (19 kg)
HEIGHT:	19 3/4" (50 cm)
DIAMETER:	7 1/2" (19 cm)
DISCHARGE:	3", NPT(F)
SOLIDS HANDLING:	1/4" (7 mm)
HOSE PORTS:	1/2" NPT (F)
PUMP BODY:	Anodized Aluminum
IMPELLER:	17-4 PH Stainless Steel
SUCTION CASE:	Rubber Lined
WEAR PLATE:	Polyethylene
SHAFT:	Stainless Steel
SHAFT SEAL:	Silicon Carbide
ELASTOMERS:	Buna N (Std)
HYDRAULIC OIL:	214-320 s.s.u. @ 100°F (64°C)
INPUT FLOW:	Max. 12 GPM (45 LPM)
OPERATING PRESSURE:	Max. 2300 PSI (156 Bar)
POWER SOURCE:	Any Open Center Hydraulic System

B0109

Specifications are subject to change without notice



HYDRA-TECH PUMPS

167 Stock Street, Nesquehoning, PA 18240 Phone: 570-645-3779 Fax: 570-645-4061
Website: www.hydra-tech.com E-Mail: htpump@hydra-tech.com

Model S3A Overall Dimensions

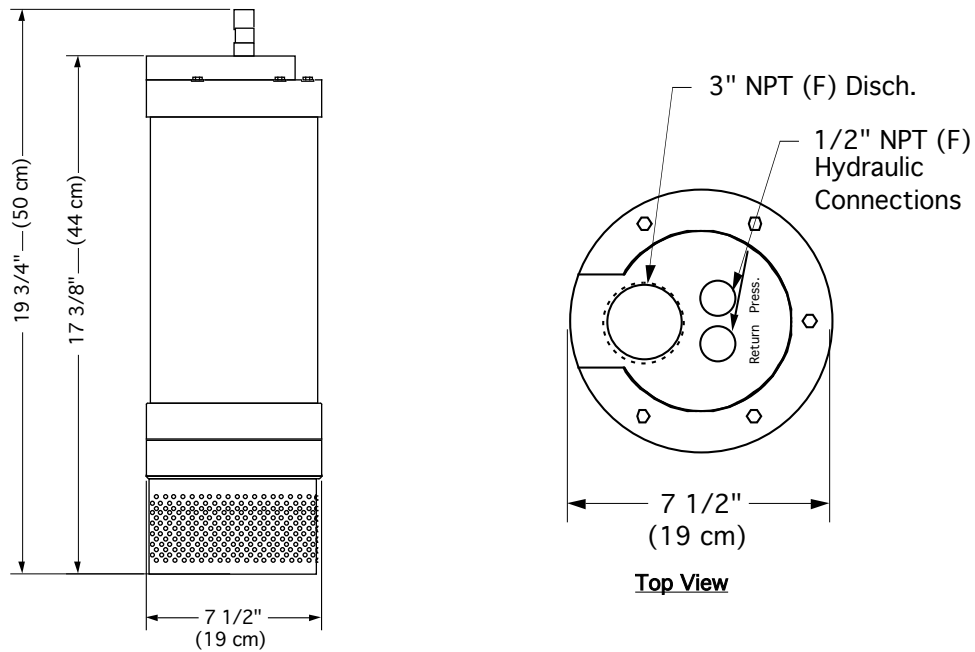

S3A Typical Performance

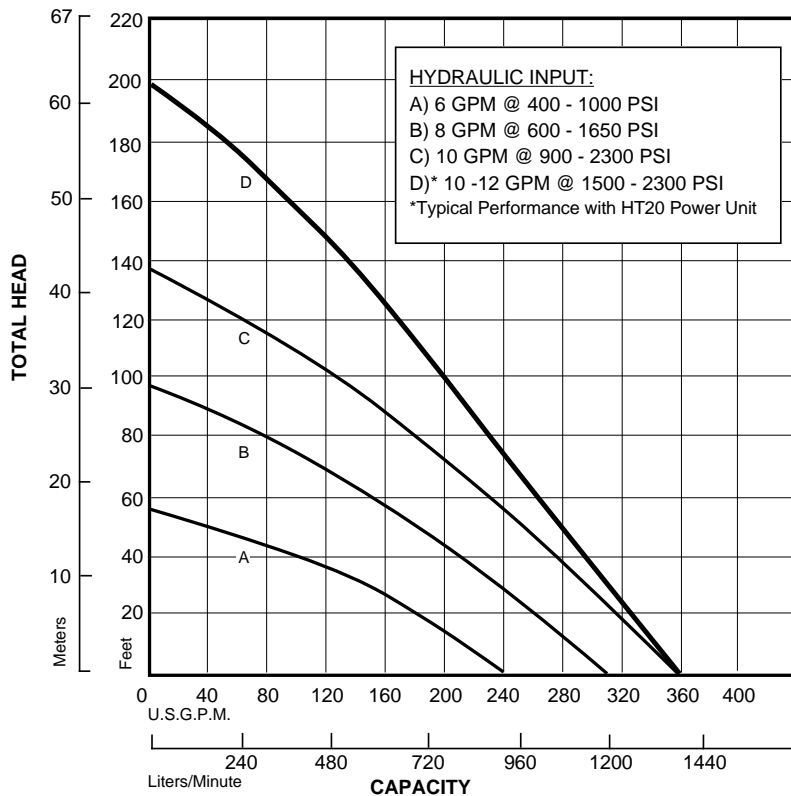

Curves are based on pumping water at 60°F. For performance curves other than shown above, consult factory.

