



# HYDRA-TECH PUMPS

## 4" HYDRAULIC SUBMERSIBLE SAND / SLURRY PUMP with AGITATOR

### MODEL S4CSL

4" (100 mm) Discharge

The S4CSL pump is designed to use in applications requiring settled solids to be put into suspension and pumped with the discharge water. Primary applications include de-silting ponds, lakes and streams. Other jobs may include filling sand bags to prevent beach erosion, tank and digester cleaning or pumping sediment from caissons.



### FEATURES

- Hardened Alloy Wear Parts
- Built-in Agitator for stirring up solids
- Oil Lubricated Seals (can run dry)
- Variable Speed hydraulic drive
- Small Size allows pump to fit through a 17 inch opening
- Safe Hydraulic Drive can be used where electric power is hazardous or impractical
- Dependable gear type hydraulic motor
- Operates with our HT20 to HT35 power units or other hydraulic power sources capable of flows to 17 GPM

### SPECIFICATIONS

WEIGHT:..... 250 lbs. (113 kg)  
 HEIGHT:..... 31" (79 cm)  
 WIDTH (@ widest point):.....16 1/4" (41 cm)  
 DISCHARGE:..... 4" NPT  
 SOLIDS HANDLING:..... 1 1/2" (38 mm)  
 HOSE PORTS:.....1/2" and 3/4" NPT (F)  
 VOLUTE\*:..... Hardened Ductile Iron  
 IMPELLER:..... High Chrome Alloy  
 WEAR PLATE..... High Chrome Alloy  
 AGITATOR:..... High Chrome Alloy  
 SHAFT:..... 304 Stainless Steel  
 SHAFT SEALS: (upper)..... Carbon/Ceramic  
 (Lower)..... Silicon Carbide  
 HYDRAULIC OIL:..... 214-320 s.s.u. @ 100°F (64°C)  
 INPUT FLOW:..... Max 17 GPM (64 LPM)  
 OPERATING PRESSURE:.... Max 2800 PSI (190 Bar)  
 POWER SOURCE:.. Any Open Center Hydraulic System

\* Optional NI-Hard volute available for highly abrasive applications

B0109

Specifications are subject to change without notice



167 Stock Street, Nesquehoning, PA 18240 Phone: 570-645-3779 Fax: 570-645-4061  
Website: [www.hydra-tech.com](http://www.hydra-tech.com) E-Mail: [htpump@hydra-tech.com](mailto:htpump@hydra-tech.com)

## Model S4CSL Overall Dimensions

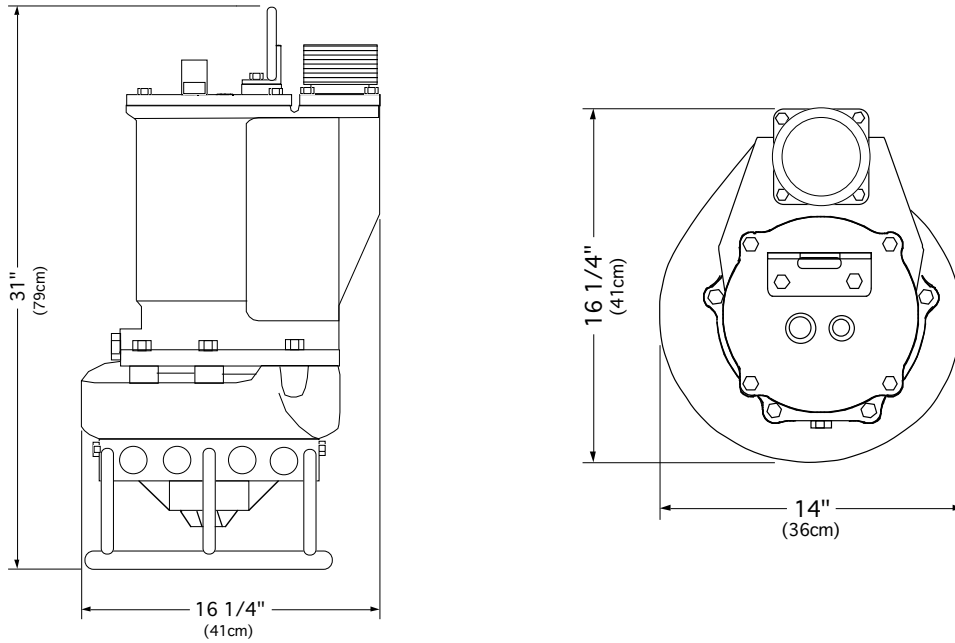

## S4CSL Typical Performance

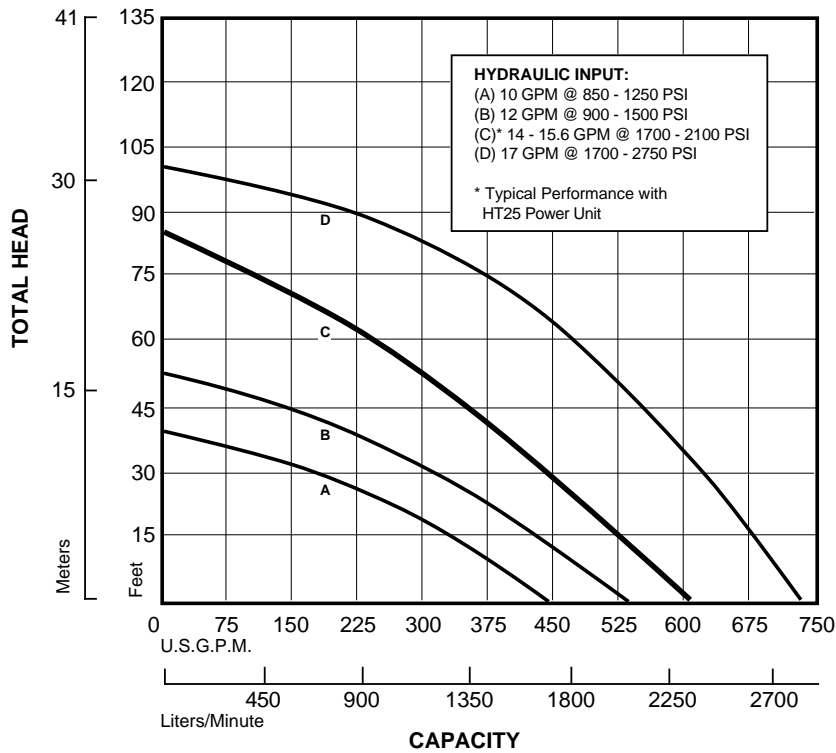

Curves are based on pumping water at 60°F. For performance curves other than shown above, consult factory.



167 Stock Street, Nesquehoning, PA 18240 Phone: 570-645-3779 Fax: 570-645-4061  
 Website: [www.hydra-tech.com](http://www.hydra-tech.com) E-Mail: [htpump@hydra-tech.com](mailto:htpump@hydra-tech.com)